

# **Go Baby Go**

## **Final Report**

**Team 22**

**Alwaleed Alhamra**

**Asrar Alkhabbaz**

**Fawaz Almutairi**

**Sultan Almutairi**

**Eric Trieu**

**Fall 2016-17**



**Project Sponsor: W.L Gore and Associates**

**Faculty Advisor: Dr. Sarah Oman**

**Sponsor Mentor: Dr. Sarah Oman**

**Instructor: Dr. David Trevas**

## **DISCLAIMER**

This report was prepared by students as part of a university course requirement. While considerable effort has been put into the project, it is not the work of licensed engineers and has not undergone the extensive verification that is common in the profession. The information, data, conclusions, and content of this report should not be relied on or utilized without thorough, independent testing and verification. University faculty members may have been associated with this project as advisors, sponsors, or course instructors, but as such they are not responsible for the accuracy of results or conclusions.

## EXECUTIVE SUMMARY

During this project a team of five mechanical engineer student who worked together to provide a project that will help a child with mobility difficulty. The team had entered the Go-Baby-Go program to aid children by improving the mobility vehicle with addressing a comfortable solution for children to be traveling freely. During the process into creating this project, the team came together with the client to figure what is needed and what requirements the client sees fit to a child's needs. The team did not only think of the child but also thought of the parents of the child. The team made a list of customer requirements and weighted them from a scale of 5, 5 being the highest priority. The most important requirement was the safety, then comes comfortability and durability. After that a weight of 3 was low cost and ease of assembly, and at a scale of 2 was aesthetic and lightweight. The team accomplished all of the customer requirements listed. The team made the build easy for the parents with having a manual to show a step by step on how the parents can retrofit the ride-on-car. The budget was also a success where parents will be spending about \$341. With all of the designs the team came up with, the team made it so that the child will be comfortable using the ride-on-car. The team changed the hard cushion and placed it with a padded cushion that came with a 5-point harness seatbelt. As for the steering wheel, it was changed and replaced with a steering joystick. The team also placed a PVC safety frame around the car, to make the child be in a safer place. The operation manual that the team made, has the specifics on how to fit the pipes on the car. As for the system of the ride-on-car, the car got equipped with a microprocessor that connects to two motor controllers which are both connected to the battery. As the first motor controller got connected to the steering motor and that controllers the back wheels. The second motor controller was then connected to the driving motors that gives direction to the two front wheels. The microprocessor was also connected to an input controller which is the joystick. With the new updates that the team had put in place, the new retrofit will be a simple and more comfortable way for a child to be playing around freely, but cautiously. Due to some issues that the team faced, after almost completing the final steps and connecting all parts together, the motor controller that connects to the joystick got burnt do to a mistake with the polarization. The team did not have enough time to replace it. Therefore, the team did not have an acceptable ride-on-car, but are expecting the next group who takes the car and works on the project could help into improving the mistakes that was done. Also another problem that occurred at the end was that the wheels could not go back being align to the center. With that issue, the team is also hoping for it to be re-looked at by the next team who will be handling the project.

## **ACKNOWLEDGEMENTS**

The team dedicates this page to thank all of the faculty that helped the team with the project. A special thanks goes to Dr. Trevas, who was our professor and whom helped the team be on track and gave the team his time and support. Michael Bair who was the teaching assistance who gave the team his time and dedication. Another thanks go to Dr. Oman who was our client. Dr. Oman helped the team to focus on what she needs. As for Dr. Yaramasu, he is a professor from the EE department whom gave the team his lab to work in. Dr. Yaramasu helped the team get a knowledge on what was going in the ride-on-car electrically. The teams sponsor was W.L Gore and Associates, who gave the team \$1500 to build this project and to make it happen.

## **ABSTRACT**

This background report discusses the background, requirement and existing design components of the 'Go Baby Go' project. The research program suggests for certain modifications to further improve the performance of the ride-on car developed under this project. The project is to design a device that assists a child with a mobility handicap, in which an option is to retrofit a ride-on-car. The client has a list of requirements that weighted based on importance and need to be met for the project. This work analyzes are already available designs and considers the new customer requirements to provide a new design that is cost effective and more comfortable to the special kids. Various aspects related to the ride-on car of this program is discussed from a managerial point of view and modifications are suggested. Existing designs by the 'Go Baby Go' club assists in the design the team decides on.

## Table of Contents

<b>DISCLAIMER .....</b>	<b>i</b>
<b>EXECUTIVE SUMMARY.....</b>	<b>ii</b>
<b>ACKNOWLEDGEMENTS.....</b>	<b>iii</b>
<b>ABSTRACT .....</b>	<b>iv</b>
<b>1 BACKGROUND .....</b>	<b>1</b>
<b>1.1 Introduction.....</b>	<b>1</b>
<b>1.2 Project Description .....</b>	<b>1</b>
<b>1.3 Original System.....</b>	<b>1</b>
1.3.1 Original System Structure .....	1
1.3.2 Original System Operation.....	1
1.3.3 Original System Performance .....	1
1.3.4 Original System Deficiencies.....	2
<b>2 REQUIREMENTS.....</b>	<b>2</b>
<b>2.1 Customer Requirements.....</b>	<b>2</b>
<b>2.2 Engineering Requirements .....</b>	<b>2</b>
<b>2.3 Testing Procedures .....</b>	<b>3</b>
<b>2.4 Design Links .....</b>	<b>4</b>
<b>2.5 House of Quality (HoQ) .....</b>	<b>4</b>
<b>2.6 Changes Made to Chapter 2 (REQUIREMENTS).....</b>	<b>5</b>
<b>3.1 Design Research.....</b>	<b>5</b>
<b>3.2 System Level .....</b>	<b>5</b>
3.2.1 Existing Design #1: Ride-On-Car .....	6
3.2.2 Existing Design #2: Playpen Harness .....	6
3.2.3 Existing Design #3: The Original Plasma Car.....	6
<b>3.3 Subsystem Level.....</b>	<b>7</b>
3.3.1 Subsystem #1: Safety.....	7
3.3.2 Subsystem #2: Steering .....	9
3.3.3 Subsystem #3: Acceleration.....	10
<b>3.4 Functional Decomposition .....</b>	<b>11</b>
<b>4 DESIGNS CONSIDERED .....</b>	<b>12</b>
<b>4.1 Design #1: The Solar Panel Car .....</b>	<b>12</b>
<b>4.2 Design #2: The Battery .....</b>	<b>12</b>
<b>4.3 Design #3: The Ride-On Baby Jeep Car.....</b>	<b>13</b>
<b>4.4 Design #4: The Jet Pack .....</b>	<b>13</b>
<b>4.5 Design #5: Dino Car .....</b>	<b>13</b>
<b>4.6 Design #6: The Walker.....</b>	<b>14</b>
<b>4.7 Design #7: Spider Chair .....</b>	<b>14</b>
<b>4.8 Design #8: Hangman .....</b>	<b>15</b>
<b>4.9 Design #9: The Pod.....</b>	<b>15</b>
<b>4.10 Design #10: Bending Bearing .....</b>	<b>16</b>

<b>5 DESIGNS SELECTED .....</b>	<b>16</b>
<b>5.1 Rationale for Design Selection.....</b>	<b>16</b>
<b>5.2 Design Description .....</b>	<b>17</b>
5.2.1: Stress/Strain Analysis: .....	17
5.2.2: Economic Analysis: .....	17
5.2.3 Safety Tip Analysis: .....	17
5.2.4 Steering Analysis: .....	18
5.2.5 Safety Analysis: .....	21
5.2.6 Website Analysis:.....	23
5.2.7 Acceleration Analysis:.....	25
<b>6 PROPOSED DESIGNS .....</b>	<b>28</b>
<b>7 IMPLEMENTATION .....</b>	<b>29</b>
<b>7.1 DOE .....</b>	<b>29</b>
<b>7.2 Manufacturing .....</b>	<b>29</b>
<b>8 Testing .....</b>	<b>33</b>
<b>9 Conclusions .....</b>	<b>33</b>
<b>9.1 Contribution to Project Success.....</b>	<b>33</b>
<b>9.2 Opportunity for Improvement.....</b>	<b>35</b>
<b>10 REFERENCES .....</b>	<b>36</b>
<b>APPENDIX A: Bill of Materials .....</b>	<b>39</b>

## Table of Figures

Figure 1 Customer Requirements.....	2
Figure 2 Engineering Requirements .....	3
Figure 3 House of Quality .....	5
Figure 4 Plasma Car .....	7
Figure 5 Roll cage on a ride-on-car with PVC pipes .....	7
Figure 6 5-Point Belt .....	8
Figure 7 Body Side Support .....	8
Figure 8 Push Buttons.....	9
Figure 9 T-Bar Handle Control .....	9
Figure 10 A diagram of how a joystick connect into the car.....	10
Figure 11 Joystick in a ride-on-car .....	10
Figure 12 Solar Panel Car .....	12
Figure 13 The Battery .....	12
Figure 14 Ride-On Baby Jeep Car .....	13
Figure 15 The Jet Pack .....	13
Figure 16 Dino Car .....	14
Figure 17 The Walker.....	14

Figure 18 Spider Chair .....	14
Figure 19 Hangman .....	15
Figure 20 The Pod.....	15
Figure 21 Bending Bering .....	16
Figure 22 Design Selection .....	16
Figure 23 Schematic .....	18
Figure 24 Am-2235 .....	19
Figure 25 Soto Diagram .....	20
Figure 26 Push Button .....	21
Figure 27 Baby car seat belt .....	22
Figure 28 Acceleration torque at steady state speed [13] .....	26
Figure 29 Ideal velocity over time graph with constant acceleration [14].....	27
Figure 30 Rotary Potentiometer [16].....	27
Figure 31 Power drill switch [18] .....	28
Figure 32 Schematics of The Parts.....	30
Figure 33 Joystick .....	30
Figure 34 Car Seat with a 5-Point Harness .....	31
Figure 35 Budget .....	32
Figure 36 CAD Drawing.....	32
Figure 37 Final Design .....	33



# **1 BACKGROUND**

## **1.1 Introduction**

'Go Baby Go' program is a research program started in 2012 by Dr. Cole Galloway to support the toddlers and children who have disability [2]. It is a partial charity program. The aim of the 'Go Baby Go' program is to provide mobility to these children at a tender age. Kids having disability finds it hard to manage with the wheelchairs and needs some mechanism to move with ease. 'Go Baby Go' program is meant to develop ride-on-cars that are specially designed for kids [3]. This project aims to provide assistance to the mentioned research program and to further simplify the ride-on-car design so as to make it more cost effective and to extend its reach to more and more kids in need.

## **1.2 Project Description**

This project mainly aims on two different aspects to further simplify the ride-on-car design. The first aspect is to improve the control system. For example, sensors can play a role with the controller for the car to move from a specific distance and to allows it to stop. Advance control features can be added to provide the safest driving conditions to make it easier to operate. The cost can be reduced through proper selection of design methods. The second aspect is to further improve upon the seat comfortability. The seat can be designed to be adjustable and adapt as per the child's physique. It must provide maximum comfort and at the same time must be liked by the child that will be using the car.

## **1.3 Original System**

### ***1.3.1 Original System Structure***

The original system is just a slight modification of a commercially available toy car. The existing design improves the ruggedness and control of the already available toy car. The prime objective of the program is to develop a cost effective vehicle and hence most of the improvements are not carried out in the presently available cars [4]. Few compulsorily required features are carefully added to the system.

### ***1.3.2 Original System Operation***

The 'Go Baby Go' program has a base model to its ride-on-car and does a small modification with respect to the child's needs (depending upon the extent of disability). In certain cases, a child with disability may have control over hand but not legs and vice-versa. In such situations the vehicle design is made with respect to the child's capability to operate. Some of the designs are switchable to different modes depending upon the child's actual need.

### ***1.3.3 Original System Performance***

The performance of the original system is quite good. The original system of the design suits well with the child's need, however; the technology is not utilized to its fullest and further comforting the children without much cost implications [5]. The available system can operate in different

modes with slight design change. The available operating modes are sitting mode, standing mode, advanced standing mode, walking mode and many others. The design gives a lot of emphasis to the safety in operation and makes sure that the kid using the car may not get hurt in any case. The present system performance is very good and is in-line with the child’s needs.

### 1.3.4 Original System Deficiencies

The system at present is satisfactory, cost effective and simple to use. However, a lot of further modifications can be done to further improve the system performance. For example, the present system did not have power control and the child has to do a-lot of steering adjustment to drive the vehicle. The seat in the ride on car is un-adjustable and all the children has to adjust themselves to it. The present vehicle had no monitoring for obstruction.

## 2 REQUIREMENTS

### 2.1 Customer Requirements

The customer requirement is mainly used to design a car that is adaptive in nature and is suitable to children having different physique. The ride-on-car had to be flexible to operate in different modes. It had to be highly durable and took loads for a longer time [1]. The vehicle had a low cost to make it affordable for the child’s parents. Vehicle aesthetic is important for the child to get attracted and start playing with it. Safety is the most important aspect for the child using the car; it must be safe to operate. Below, is a list of the customer requirements, with the weight of each category with 5 being the highest in importance. With the weighting came from the client who approved the customer requirement, and whom ranked each CR.

Customer Requirement	Weight
1. Low cost	3
2. Ease of Assembly	3
3. Safety	5
4. Aesthetic	2
5. Acceleration/Deceleration Control	4
6. Comfortability	4
7. Lightweight	2
8. Durable	4

Figure 1 Customer Requirements

### 2.2 Engineering Requirements

There are several engineering requirements that the team had in plan to be met for the design that is getting retrofitted. Some of them included; the weight should not exceed 130 lb. While the weight is a safety aspect, for the particular device to be stabilized with the child in it. Also another reason is for the family to be able to move it easily and comfortably. For a child’s safety, there should be no sharp edges and no sharp corners.

Another ER is the seats need to be comfortable for the children that are using the cars. Lastly, the team had a requirement for the speed to be adjustable and to start accelerate from 0 to 5 Mph.

Engineering Requirement
Weight <130
No sharp Corners
Battery Max 12V
No sharp edges
speed 0<2.5<5 Mph
Tolerance

Figure 2 Engineering Requirements

## 2.3 Testing Procedures

### 1.Speed:

In the engineering requirement, it is stated that the speed of the car should be between 1-5 mph. Test procedure for this requirement entails driving the car and seeing what limit of speed it can reach. The car should be driven at full throttle since that is what the child is likely to do. If the speed is in the range, then the model is alright, but it is above it, the car needs some modifications.

### 2.Weight:

To test the weight of the car, it can be measured by the use of a weight balance. Due to the irregular nature of the car, it can be placed on a plank of wood that have been pre-weighed so that there is no damage that will happen to the car. If the car is weighed and found to be more than 130lb, then there are some modifications that may need to be done so that the weight is brought down.

### 3.Car safety:

Safety of a kid in the car will be dependent on the makeup of the car in terms of its riveting and welding to test if it has smooth edges, one should run a hand over all the edges and see if the hand gets bruised along the way by the edges. If the hand does not get bruised in any way, one can then conclude that there is no danger that is posed to the child in the car.

### 4.Comfort of the child:

The child comfort is depended on what they shall be sitting on. The seat that they are sitting on should be soft. A soft pad should be placed on the seat and the headrest of the sitting area. One can hard press on the sitting area and see of it is ideal in terms of its hardness or its softness for the child who will be riding the car.

## 2.4 Design Links

### 1.Safety:

In our design, we have improvised the safety seat of the child to include a harness that will strap the child into the seat. This is a feature that was not there before. The harness that we have improvised is in such a way that a child is strapped from both shoulders and the waist area. The child is secure in this position and cannot move even if the car crushed.

### 2.Speed:

The new model has a new power system that will be used to control and accelerate the car. The car will be installed with a 12V battery. The battery will have three switches; one will allow 4V, the other will allow 4V and the final one will allow 4V. Each of these switches can be flipped independently. When all the switches have been flipped, the car will roll at the maximum speed. The car will roll at a lower speed with each of the other lower speeds being engaged.

### 3.Comfort:

It is presumed that the child will have a small ability to drive the car and this is the reason the child needs to be strapped to the seat with a harness. To increase the comfort, we use the will change the steering wheel as the current one is circular in nature to one that that is linear. It will have two handle bars and the kid can hold them. These handles will be used by the kid as a means to hold themselves and as act also as the steering of the car.

## 2.5 House of Quality (HoQ)

While designing for the work, a complete attention is required on quality and safety of the ride-on car. The design must be such a way that, it can go in line with the customer's need. After going through the customer needs, the design team must figure out certain crucial areas and focus on

them to get the required quality. Emphasis must be put on and fine tuning must be made until the required quality is met. Any compromise with the quality will ultimately lead to unpredicted failures and will totally mess up the situation. Proper weight has to be given to each of the customer's need and design work has to be carried out accordingly. The engineering requirments is place and decided upon what will be best to change in the car that will include safety, comfort,

House of Quality (HoQ)											
Engineering Requirement		Weight	Weight <130	No Sharp Corners	Battery Max 12V	No Sharp Edges	Speed 0<0.25<5 Mph	Tolerance			
Customer Requirement											
1. Low cost	3	1	1	3	1	3	1			Weak	1
2. Ease of Assembly	3	9	3	3	3	3	3			Medium	3
3. Safety	5	3	9	3	9	9	3			Strong	9
4. Aesthetic	2	3	3	9	3	9	9				
5. Acceleration/Deceleration Control	4	3	3	9	3	9	9				
6. Comfortability	4	9	9	3	9	3	9				
7. Lightweight	2	9	1	1	1	1	1				
8. Durable	4	9	3	3	3	3	9				
<b>Absolute Technical Importance (ATI)</b>			46	32	34	32	40	44			
<b>Relative Technical Importance (RTI)</b>			1	4	5	4	3	2			
<b>Testing Procedure (TP#)</b>			2	3	1	3	1	4			
<b>Design Link (DL#)</b>			1	1	2	1	2	3			

Figure 3 House of Quality

and speed. With the engineering requirement, it got ranked as 1, 3, and 9; 9 being the strong term in relation to the customer requirements. Shown in figure 3 above, the ATI and RTI was calculated and ranked.

## 2.6 Changes Made to Chapter 2 (REQUIREMENTS)

During the semester some updates and changes were made. One of the major change that was made was with the customer requirement. As the team spoke to the client, and while the client saw that there was not enough time to work on the acceleration/deceleration, the client asked and preferred the team to look into working on the issue that occurred which was making the wheels to go straight rather than working on the jerking motion.

## 3 EXISTING DESIGN

### 3.1 Design Research

The existing designs under the 'Go Baby Go' program involve an in-depth analysis on the actual requirement and listing the possible solutions. Each of the listed solutions are further analyzed to select the option that best suits the requirements [5]. The selected option is then studied for the practical feasibility. A particular design is selected after a serious study and testing.

### 3.2 System Level

Research in the area of providing power cars to kids started from late 1980s [1]. Over the period of time with the advent of modern technology many modifications have been brought about. The table below shows the development in the design area.

Table 1. Design Research Over Time [1]

Year	Car Design
1980	Adapting Power Chairs for young children
1990-95	The Cooper car
1995-1999	Go BOT
2000	The standard Paediatric Power Chair
2005-2010	Mobile Robots
2010-2015	Go Baby Go Modified Ride-on car

Technology has played its role over time and a lot of modifications have happened. However, in recent times with the beginning of 'Go Baby Go' program, much of the emphasis has been put on the cost control and simple design. The objective of the programs is to provide low cost and maximum comfort vehicles to the kids. Therefore, certain compromises have been made with the features to make it available to maximum kids with disabilities as possible.

### ***3.2.1 Existing Design #1: Ride-On-Car***

The ride-on-cars are modified due to the child's disabilities and parent's requirements. The modifications differ from one kid to another. Some ways that the cars were modified are; playing around with the wheels; change the steering wheels, cushions, safety system modification, and much more. Some kids might need entertainment, such as adding an iPod dock, or even just a radio system.

### ***3.2.2 Existing Design #2: Playpen Harness***

The Harness Play Pen is a mobility assisting system that utilizes a safety harness and pulley system. The child is secured into a harness and moves around within a 10'x10' play area. There is a pulley system that gives assistance to a child by applying additional leverage support for the child to walk. The system allows the child to move freely within the given area [10].

### ***3.2.3 Existing Design #3: The Original Plasma Car***

The Plasma Car is human energy powered self-propelled toy that is designed for children to move around. It uses the twisting motion of the steering wheel that utilizes the natural forces of inertia, centrifugal force and friction to move the car forward and backwards. The Plasma Car does not require any external power sources and has a durable structure for a child to use safely. The physic fundamental that the car incorporates allows any user to operate the car quickly [9].



Figure 4 Plasma Car

### 3.3 Subsystem Level

The main area of focus is on the improvement of the controllability, introduction of power wheels and improvement on the seat efficiency. The controllability can be improved by using microcontroller based systems. Powerful microcontrollers and sensors can be used to design the circuit and improve controllability. Introduction of the power wheels will be helpful for the kids in assisting the steering to drive the vehicle. The power wheels can be used through proper mechanical design and powerful drive motors. The seat ergonomics can be enhanced by understanding the baby sitting posture and design accordingly. The special kids may have certain abnormal body posture and seat efficiency must be according to the physical examination of the individual kid. Some software can be developed that will take the inputs on the kid's physical size and will provide the seat design with parameters.

#### 3.3.1 Subsystem #1: Safety

##### 3.3.1.1 Existing Design #1: PVC Pipe around the car frame

The roll cage is built with PVC pipes mounted around the car frame [8] Figure 4 below is one way of how PVC pipes protect the child while playing around with the ride-on-car.



Figure 5 Roll cage on a ride-on-car with PVC pipes

### 3.3.1.2 Existing Design #2: Seat Belt

A seatbelt is the easiest and the most practical safety product a kid can have. It can be bought off the shelf from any hardware store. The seatbelt idea is going to be taken from an F-19 airplane. The belt is going to be a 5-point cross belt, with an example shown in figure 6 below.



Figure 6 5-Point Belt

### 3.3.1.3 Existing Design #3: Body Side Support

Body side support is constructed with foam sheet and can be adjusted. It is a support system for the child, while it straightens out the body, and also helps with the safety of the child, as shown in figure 7 below [8].

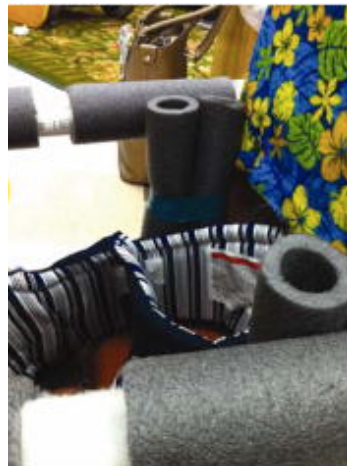

Figure 7 Body Side Support



### 3.3.2 Subsystem #2: Steering

#### 3.3.2.1 Existing Design #1: Push-button switches of various sizes

With a change of wires, the ride-on-car can be controlled with buttons, shown in figure 8 below. The push button switches can be plugged into the connector directly allowing the use of various steering systems. These buttons are placed instead of the steering wheel [8].



Figure 8 Push Buttons

#### 3.3.2.2 Existing Design #2: Bar handle style with different sizes of PVC pipe

Basic steering-drive system options include a round steering wheel with push-button switches of various sizes and a bar handle style with different sizes of PVC pipe shown in figure 9 below [8].



Figure 9 T-Bar Handle Control

### 3.3.2.3 Existing Design #3: Joystick

A child with muscular diseases have a hard time controlling a steering wheel. A joystick is the best option to steer a ride-on-car. There are two types of joysticks, one is controlled by the arm and the other is controlled by the hands and the fingers. This depends on the kids' ability and comfort when they move their hand. In figure 10 below, is a diagram which is one example of how a joystick could connect to a ride-on-car [6].

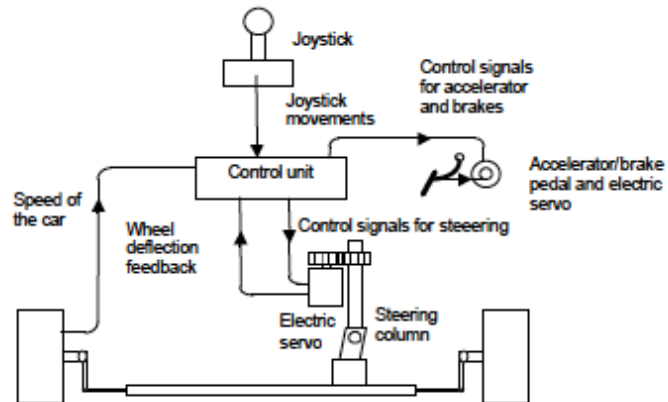

Figure 10 A diagram of how a joystick connect into the car

### 3.3.3 Subsystem #3: Acceleration

#### 3.3.3.1 Existing Design #1: Lever on a ride-on-car

One idea was to play around with the acceleration lever on the car. Some ride-on-cars have that lever, where the side of the lever has a screw which can be removed, and with that it plays with speed variance shown in figure 11 [7].



Figure 11 Joystick in a ride-on-car

### 3.4 Functional Decomposition

Below is a small functional decomposition for our team’s ideas and steps to figuring out the process behind the re-design. The team needed to do more research and testing to figure out what types of switches was to be provided the desired results. The functional model showed what exactly needed to be done at first. Also it is good so the team could set their mind and time to work with these situations. When this model is done, then the team could go to a second process. The three main ideas all come back for the energy to make the steering device work. The seat, electricity, and human energy all have impact on the design itself. They are the major aspects on what needs to be changed and redesigned, and with this model the team will start on working and taking the parts out and fixing the model.

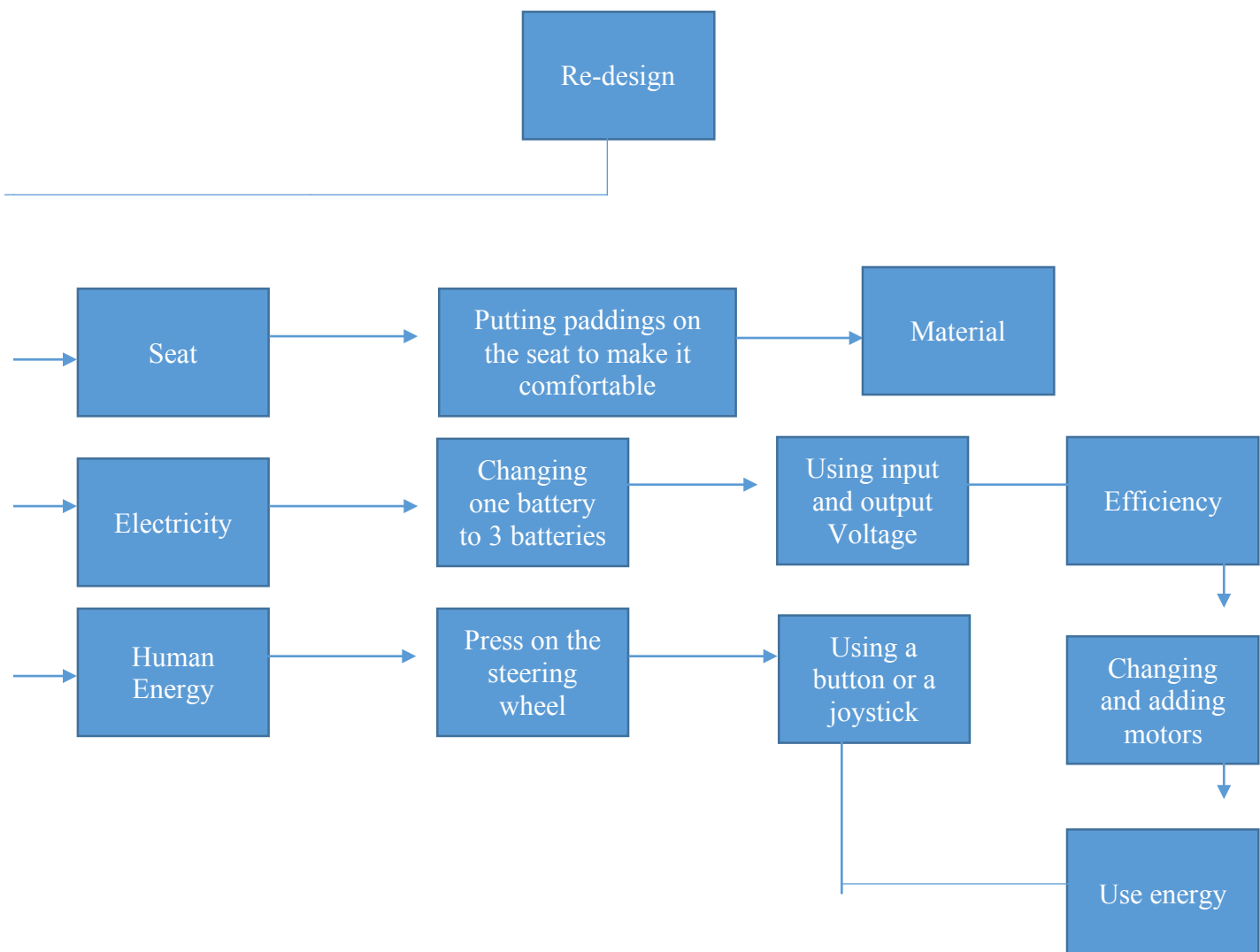

## 4 DESIGNS CONSIDERED

### 4.1 Design #1: The Solar Panel Car

The solar panel car, is design to help not only the child in-need, but also with the environment. This car is going to be designed in a way where the car will have a solar panel on top of the car, and it will then have a cross-belt, where the kid is also safe to move with the solar energy. This can have a bad side to it, this car is going to cost a lot, also it will be hard to assemble. The car will not have durability, and will be heavy to work with. But for the upside of the solar panel car is that the car could have a better and probably more stable acceleration/ deceleration. As shown below in figure 12, is a figure of the car.

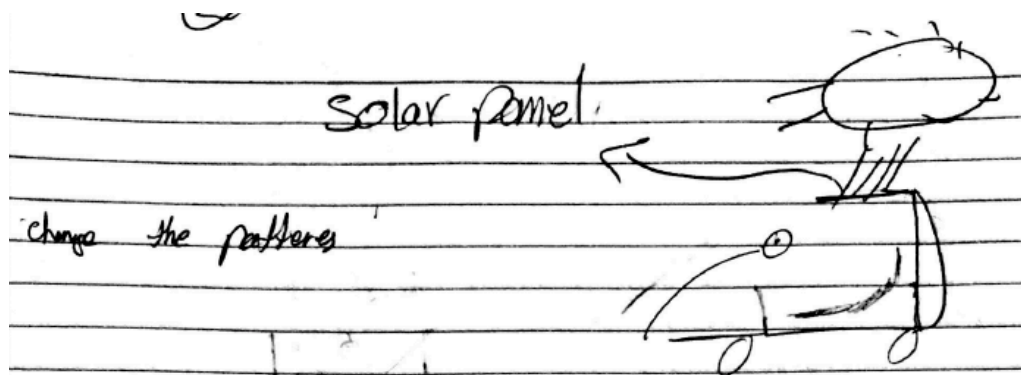

Figure 12 Solar Panel Car

### 4.2 Design #2: The Battery

The battery in the figure 13 below will be based on a way for the child to have control over the speed. The battery will have 3 switches and the first 2 switches will have speeds of 1 volt, while the third battery will have 2V. when the child turns the first switch on, the car will have a speed of 1 V. When the 2<sup>nd</sup> switch turns on, the first and second battery will work together increasing the acceleration to 2 volts. While the third switch is turned on, all of the 3 batteries work together and gives the car an acceleration of 4 volts.

The good thing about this prototype is that the child will have control of the speed, and not be stuck with a constant speed.

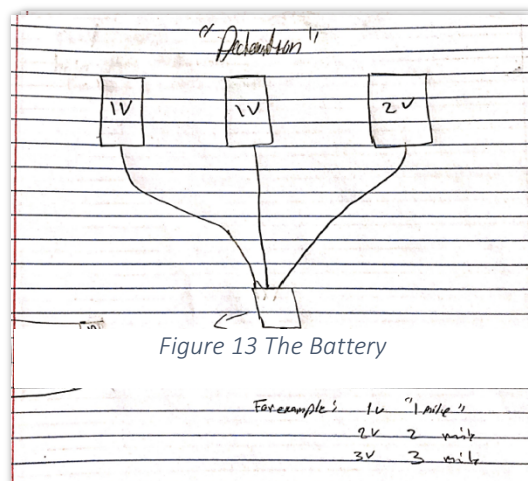

Figure 13 The Battery

### 4.3 Design #3: The Ride-On Baby Jeep Car

The ride-on car is one of the most comfortable design for a child with disability. This prototype is main source on the go-baby-go program. The only difference with this car is that the seatbelt will be a cross harness to support the child's back. The steering wheel is going to be change and be a circular wheel which is a touch pad.

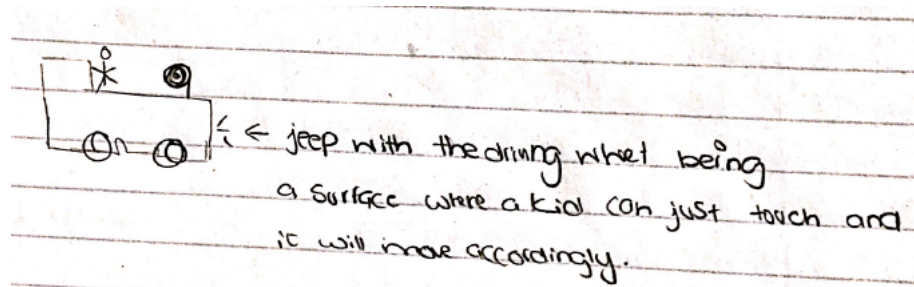

Figure 14 Ride-On Baby Jeep Car

### 4.4 Design #4: The Jet Pack

The Jetpack as shown in figure 15 below, is particularly a jetpack that can be sold in stores or online. This jetpack is a fun, and wild ride. With it having a higher and much faster acceleration/ deceleration but it can also be pricier, hard to assemble, it is also less safe for a child with a challenge to work around with. The good thing about the jetpack though, it has a good aesthetic.

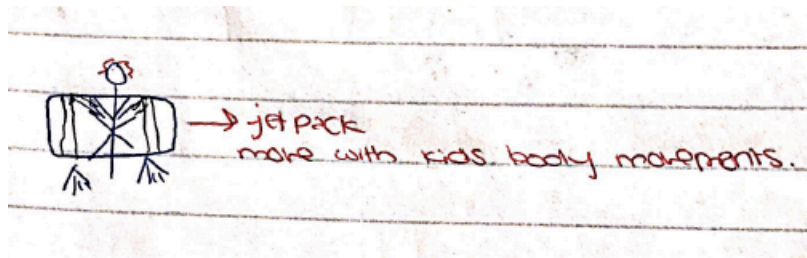

Figure 15 The Jet Pack

### 4.5 Design #5: Dino Car

Something similar to ride-on jeep car is the dino. The dino has the same features of the ride-on car such as the pricing, ease of assembly, safety, aesthetic, a reasonable acceleration/ deceleration, and also will be durable and light-weighted. The dino car will be the same as any electronic toy car, but with a harness that will be placed as a cross belt to protect the child from falling off and to protect the child's back from bending, also to pull the child from any sudden motion. Below is a figure of the dino car.

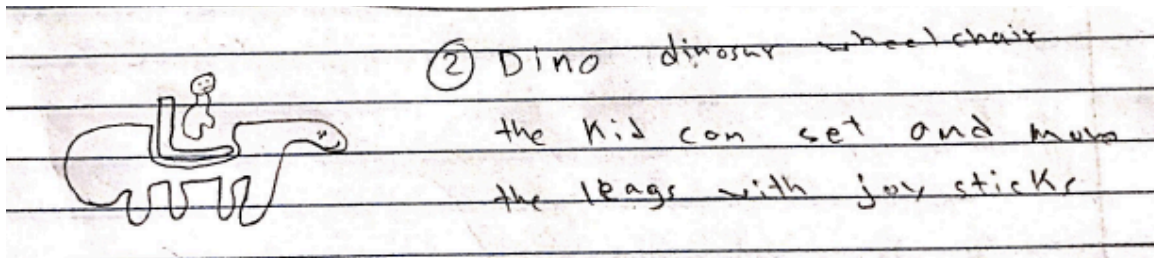

Figure 16 Dino Car

#### 4.6 Design #6: The Walker

The walker is a circular stand which has four wheels shown in figure 17 below. The wheelchair is a standup/ sit-down chair, that is very safe for a child. The child can be placed into the circular space, which has a pamper like seat. It is very comfortable and a parent wouldn't worry about the child's safety.

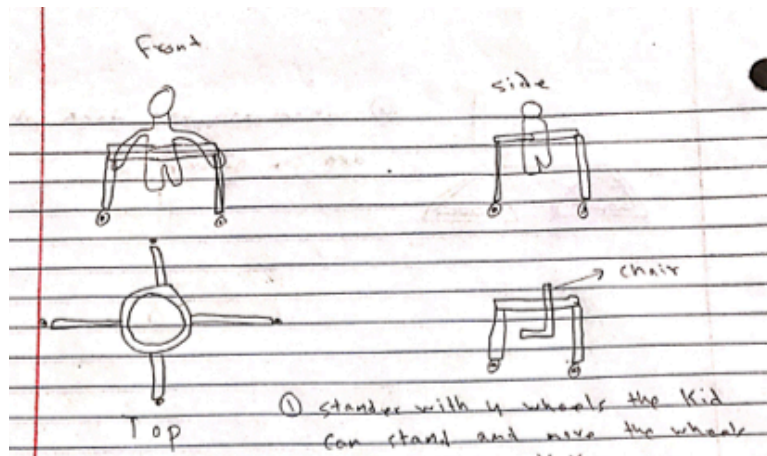

Figure 17 The Walker

#### 4.7 Design #7: Spider Chair

A spider chair has 8 legs. It's probably like a walker, but instead, the chair looks like a spider. It is also controlled with a joystick. The price will be similar to the ride-on-car with a higher aesthetic, and is safer. While it has a lower acceleration/deceleration, due to the weight of the chair, also it is harder to assemble.

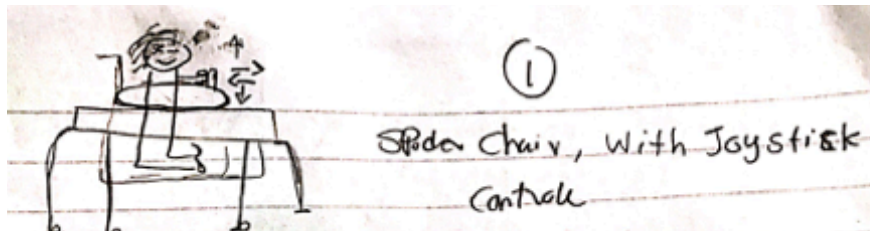

Figure 18 Spider Chair

#### 4.8 Design #8: Hangman

This design literally looks like a hangman game. This design is support by a beam that is connected to a wheeler which both are connected to a bounce string. The child will be placed into the bungee rope chair were the child could bounce off and move at the same time. The cost is the same as the ride-on-car, with the same safety and aesthetic. The disadvantage is that it's less safe, less comfortable, and has a lower acceleration/ deceleration.

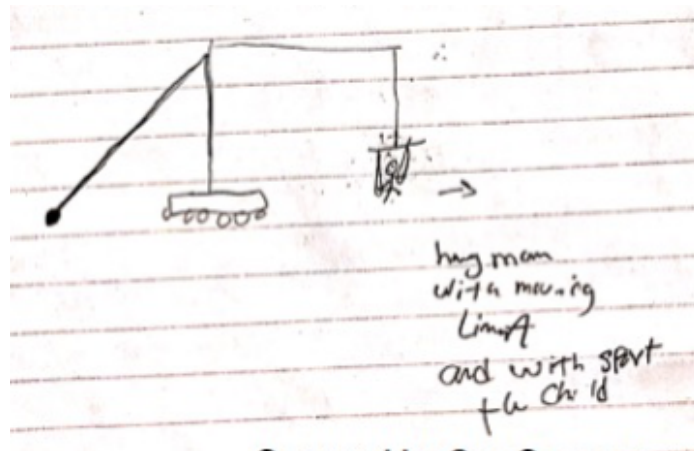

Figure 19 Hangman

#### 4.9 Design #9: The Pod

The pod is a device that kind-off looks like an egg. It is electronically powered by a motor vehicle, shown in figure 20 below. Due to its motor, the pod is more expensive than the ride-on-car, but is safer due to the child's seat being covered with foam. The acceleration/ deceleration is better to control due to its electronic features. With a child being placed into the pod, it may be less comfortable for the child. It might be a bit tight for the child to have the space to freely express him/herself.

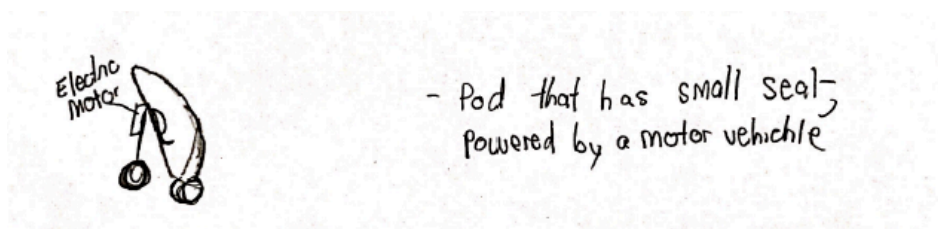

Figure 20 The Pod

## 4.10 Design #10: Bending Bearing

This concept has the same as the ride-on-car cost. The child can bounce up and down, which creates a propulsion of the system. This concept has a harder assembly and is less safe. This concept helps the child to move around a bit freely, but at the same time makes the child a bit tired from all of the movement. The bearing is a light weight device.

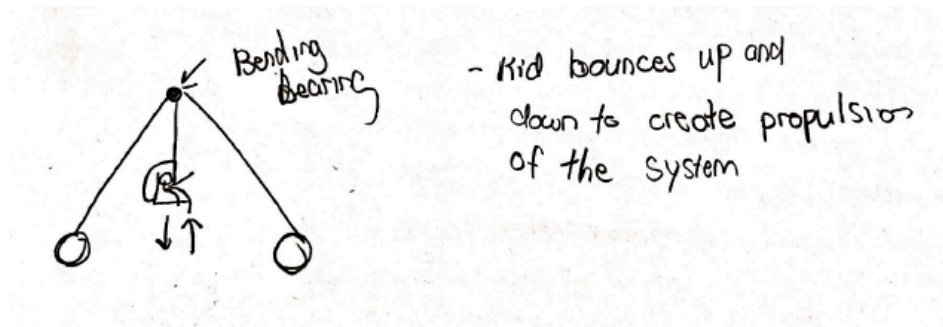

Figure 21 Bending Bering

## 5 DESIGNS SELECTED

### 5.1 Rationale for Design Selection

From all of the 20 designs the team came up with, which includes the 10 above; the team made a Pugh chart with all of the customer requirements. The Pugh chart is assembled with plus, minus, and s signs. These indicate if the device due to the requirement is better, lower, or the same as the datum. The team choose the ride-on baby jeep car due to it being similar and probably one of the best choices for a go-baby-go project. As shown in the figure 22 below, is a sum of the four best concepts that fulfilled the datum's priority.

Concept/ Criteria	Jeep	Battery Acceleration	Walker	Dino
#s	7	3	17	18
Low cost	D	+	+	S
Ease of Assembly		-	+	S
Safety	A	+	+	S
Aesthetic		S	-	+
Acceleration/ Deceleration Control	T	+	-	S
Comfortability		+	S	S
Lightweight	U	S	S	S
Durable		S	S	S
Total +	M	4	3	1
Total -		1	2	0
Total S		3	3	7

Figure 22 Design Selection



## 5.2 Design Description

### 5.2.1: *Stress/Strain Analysis:*

The stress analysis is based on the ability to withstand pressure in a coalition of the toy car. The stress analysis of the car is based on the ability to withstand pressure. There stress that needs to be withstood is the stress that is from the possible collision. A coalition is from objects in motion in which case they will have a kinetic energy that will be from the  $F=MV^2$ . The PVC pipes that have been used should have stress strength that will be equal to the force that will be produced by the kinetic energy as above. The top speed produced by the 12V should be used in this analysis for the force that the PVC pipes should have.

### 5.2.2: *Economic Analysis:*

The major component that needs to be purchased for this project is the power battery and a model jeep that was chosen. The cost of the jeep will be about \$299. The cost of the battery will be about \$30. the PVC pipes and the connectivity will probably cost about \$20. The 5-point belt will be around \$10. Also, the push button will cost about \$17. The total cost will therefore will roughly come out to be  $\$299 + \$17 + \$30 + \$20 + \$10 = \$376$ . This will be the startup amount that will be used.

### 5.2.3 *Safety Tip Analysis:*

One of the more important calculations will be the calculation of the friction force when the car will be taking a corner. At this point, if there is a skidding of the tires, the car may actually roll over and this may be injurious to the people that will be riding the car. When, a corner is getting negotiated, there is a force that comes to play and this force is the centripetal force. This force is given by the equation;  $F_c = MV^2/r$ . In the application of this equation, it will be equated to the friction force by the relationship;  $F_f = \mu F_c$ . From this relationship, it should have made sure that the value that is obtained for the  $\mu$  should be greater than 0.1. At the top speed of the car, the value of  $\mu$  should stay below 0.1 to make sure that there is safety of the kid. With a scenario that some might think about when a child rides a ride-on-car is that what if the child is on a slope, or is turning within a curve, what will happen, and what is the angle that will be its maximum before it tips over. The most important thing that parent wants for a child is to be safe,

no matter where, or what the child is on, safety is what a parent looks for in any object the parents buys for a child, especially if the child needs help, or has difficulty to move around.

In the schematic in figure 23, is a theoretically scenario, where the car is going towards this page, with the X and y co-ordinates. The components will be divided up into two sums in the forces of Y and X shown in the equations below.

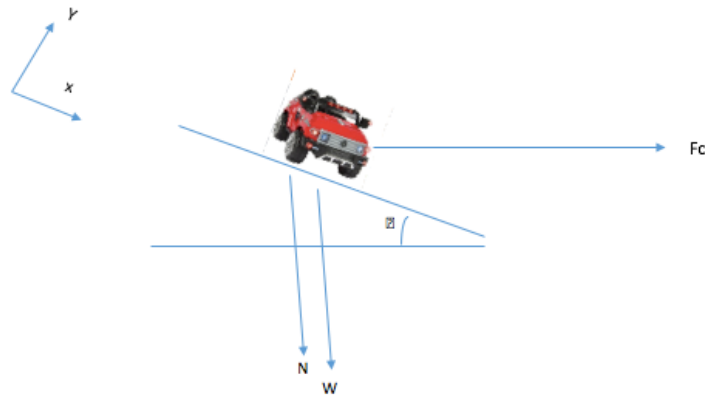

Figure 23 Schematic

$$\begin{aligned}\sum F_y &= N + F_c * \sin\theta - W * \cos\theta \\ \sum F_x &= F_c * \cos\theta + W * \sin\theta - \mu N\end{aligned}$$

N= Normal Force

Fc= Gravitational Force  $F_c = m * \left(\frac{v^2}{r}\right)$

R=radius of path

V=speed

M=58.967

W= 58.967\*9.81= 578.46627

$\mu$  = Coefficient of Friction

To find the coefficient of friction is in the equation below:

$$F = \mu * N$$

Within this ride-on-car the maximum speed is going to be 8Km/h, and when converting it will be giving us 2.22222 m/s.

For the centripetal acceleration it must be a net force and a net force always causes an acceleration in the direction of the net force. As for the centripetal force is a force that causes motion in a curved path. This is provided in the equation above. This circular path acts towards the axis of rotation [11]. Another way to figure out the gravitational force is by looking at the angular velocity which tends to help when figuring an angle. An equation is shown below.

$$F_c = m * r * \omega^2$$

$\omega$  = angular velocity

#### 5.2.4 Steering Analysis:

The ride-on-car is a very important device that is used by people from all around the world. It has the perfect shape and design formula that makes it one of the best ways for a child to travel and move around. This is one of the best ways in which issues facing the use of reliable materials for the manufacture of such a very important device can be effectively realized.

The ride-on-car making is a project that utilizes the most effective light materials that include tough wheels that do not disappoint. The variables involved in the performance of this design structure include a great deal of physics input that can be relied on for posterity purposes. Other elements can include circuit, dynamics, and efficiency. One of the ideas that the team came up with is replacing the steering wheel system for the jeep car and placing a joystick. The joystick is very efficient in the delivery that takes control of the car. The joystick acts as a proficient way of offering control and direction of the car thus making it useful for a lot of children. The system is perfectly designed in order to capture the variables involved in determining the direction and stability of the main ride-on-car. The ride-on-car steering system uses calibration and gives the speed with careful amount of precision.

Due to the steering features in the ride-on-car, the composite will be slightly different than a normal car. This ride-on-car is going to be supported with a 12 V battery. With it being an electric car, the car will be based on a circuit board. A way to look at the steering system to work is to look for the safeness that can be the most important aspect of the steering wheel. For example, if the car is set to its highest speed; which is 8 Km/h, the angle of the steering wheel must be turned approximately and constantly. This ride-on-car can turn to approximately 10 revolutions due to the equation below [19].

$$R = v_{max} * dof \ wheel * \frac{1}{28(\pi)}$$

$$R = 88 \left( \frac{in}{s} \right) * 10in * \frac{1}{28(\pi)}$$

$$R = 10.004 \ in/s$$

The steering wheel will be connected with a window motor Am-2235 shown below. This motor is for a 12 V input, weights 1.11 pounds, a current of 5 amps, gives a torque of 70 in-lb, and gives off a maximum power of 200 Watts.



Figure 24 Am-2235

The turning angle will be connected to the Am-2235 motor. This motor will be connected to the circuit board by having the connections parallel to give the car its maximum speed. With the motor connected to the steer motor angle, the steer motor angle will give the function to the Arduino, which will be the brains of the system. This system is going to be the safety system. For example, if the child is on maximum speed and turns the steering wheel into a wrong angle, the Arduino, which is connected to the steering wheel system, can give the code to the steering wheel's brain, to do it but in a slower motion and safely. This can give the child a more safe and stable vibe while in the ride-on-car.

An equation below can be a simple way to show how the turning angle, steering motor angle, Arduino, and the steering wheel angle are connected.

$$Tangle = Cconstant(SM Angle)$$

The Arduino can be given in a Soto code for an angle configuration. When the Arduino is placed in a diagram it could be an easier task for a start-up setup. A start-up diagram can be shown below in figure 25.

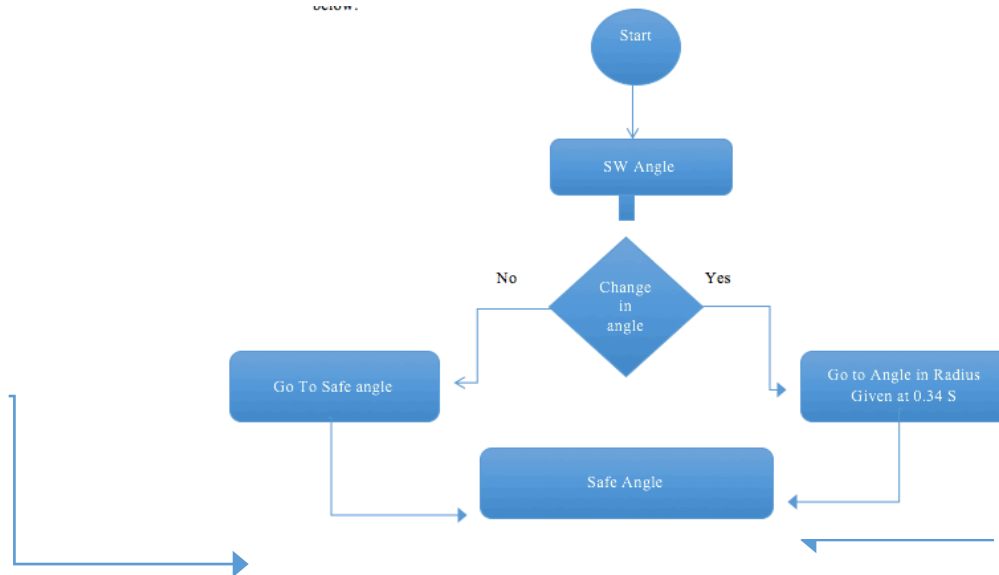

Figure 25 Soto Diagram

From the diagram above, it shows an easy step procedure that when a child starts to turn the steering wheel in the right angle that will be calculated, it will do so within 0.34s for the turn. On the other hand, when the child turns in an angle that will be a result of its falling or tipping over, the Arduino will set itself to go to the nearest and safest angle that a child should be turning. With both cases, the turns will result into a safe angle turn. The safe angles of the steering could be calculated using forces with summing up the forces in the Y and X-axis. An equation that could be used is shown below [19].

$$angle = \text{Atan}^{-1} \left( \frac{\text{Wheel base}}{\text{turning circle} - \text{car width}} \right)$$

Another idea that the team came up with is replacing the steering system for the jeep car with a big dome push button. This 12 V button can be adjusted on the parent's specification, which can allow the button to a lower profile. This button is a new tick for a child to handle. This button offers an excellent performance while operating. This button can help a child push and accelerate the ride-on-car.



*Figure 26 Push Button*

### **5.2.5 Safety Analysis:**

Ride-on baby Jeep Car is built in a comfortable design that can suit children with disability. It uses a cross harness seatbelt to provide support for the child's back. It has comfortable seat design that can be adjusted to suit the physique of the child. The comfort makes it likable by a child that uses it. It has improved controls with smooth designs for the safety of the child. The child can operate it while seated in a safe manner that protects potential injuries when using the toy.

Among the key design structure for the Ride-on Jeep Car include a wider base covered by the wheels. This works alongside a central positioning of the rider's seat to provide some centrifugal balance. The rider cannot fall off and be injured due to centrally balanced design. Instances of rollover become increasingly difficult unless an adult who has a higher center of

gravity decides to board the Ride-on baby Jeep Car. This instance is rarely possible because the limbs of an adult can hardly fit into the space holding the seat for the driver.

The tires are also wide enough to prevent ground slip off. The seat should be designed in an adjustable model for flexibility. Different kids have varying physiques and body sizes. Some have longer limbs that require more space between the steering wheel and the seat. Others may also be too short, maybe due to a younger age, making them unable to reach the steering wheel. A rigid seat would be uncomfortable for such kids.

The design meets customer requirements, as it lacks sharp corners of edges that could jeopardize child safety. It's slower acceleration speed makes it safe for use by children.

The PVC pipes that make the framework have a maximum tensile force of 100N. This is the maximum force for them to crush and make the kid unsafe. We need to use this to calculate the maximum speed that the car should attain and the child to be safe.

$$F = 1/2MV^2.$$

$$100 = 1/2MV^2$$

$$100 = 0.5 \times 50 \times V^2$$

$$V^2 = v(4)$$

$$= 2\text{km/hr}$$

The car should not be designed to have a speed that is greater than 2km/hr for the safety sake of the child in case there is crush against a wall. It should however be made sure that the child is strapped to a seat with a seat belt like the one shown below in figure 27



Figure 27 Baby car seat belt

The overall weight of the Ride-on baby Jeep Car is below 130lb. This means that it can easily be pushed if it breaks down. It also does minimal harm when it runs over materials of body parts of children. This improves the children's safety. The weight also ensures the stability of the toy, making it safe for children to climb on top of them.

One of the important safety issues is safety when making corners. The total weight of the child and the car will most likely come to 50kg. The most critical corner that the child can negotiate would be 1 meter in radius. This force at a maximum speed will yield

$$F_c = MV^2/r$$

$$= 50 \times 2 \times 2 / 1$$

$$= 200 \text{ N}$$

Every time taking a corner at maximum speed, there will be a centripetal force of 200N. To prevent a slip up of the car on a flat area, we need;

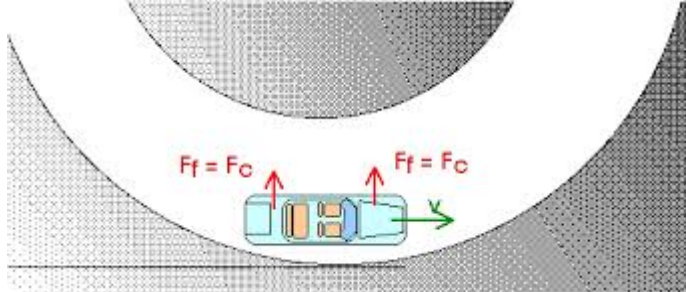

Force around corners of the baby car

$$F_f = \mu F_c$$

$$200 = \mu \times 500 \text{ N}$$

$$\mu = 200 / 500$$

$$\mu = 0.4$$

Any coefficient that is less than 0.1 is dangerous. We have 0.4 which is greater than 0.1. This means that at top speed, the baby car can make a curve and would still not skid off the road and hence safe.

In the event that the child rider slips off the Ride-on baby Jeep Car, their safety can be secured through guard bars made with PVC pipes that run around the entire car frame. This creates some sort of a roll cage that prevents the child on board from slipping off the car, for instance, if they hit an obstacle. Other than this, the seat has a harness belt that the child can pull and strap on before they ride the baby Jeep Car. This is a redundant design for safety, as children may often fail to see the risk in riding their toy car.

Very few children may actually remember to put the strap on, as most see the Ride – on baby Jeep Car as a form of entertainment and recreation, not harm. For this reason, the PVC roll cage would have to provide safety to the child on the baby Jeep Car without requiring their input or discretion. The fact that the child has much control on the Ride-on baby Jeep Car’s acceleration makes it safe for use by children. They can choose when to increase acceleration and when to reduce it. For instance, they can avoid hitting obstacles because they can easily decelerate the Ride-on baby Jeep Car.

### 5.2.6 Website Analysis:

Websites have become one of the easiest ways of passing and dissemination of information where there is a group that is involved. It cuts down on the communication time and the resources that are needed to make the communication a success. The other thing is that websites are a good way of reaching to other people of which one have a need to make contact. We are undertaking a project on Go Baby Go. In undertaking our project, we are a team that works together as well as individual exploits. However, we all needed to keep an update of what

we are doing and communicate with the rest of the members of the group. In our project, we decided, to make a website that would help us to complete our project successfully. Since it is expensive to buy a website we decided to make a website ourselves.

We made the website with software that is called Adobe Dreamweaver CS6. The Adobe Dreamweaver is one of the best sites for making a website. First of all, it is free to use this software to use this website. As students, we did not have the money to pay someone to make us a website that will cost us a lot of money. The other thing is that this software is very easy to use. The software has an inter-phase that holds many templates. One can choose any of these templates and build on them to make the website that they so desire. One does not have to be a computer wizard to use this software. We customized the template that we choose and added the features that we found were important for our site.

One of the most important features of a website is that it should have a computer and a mobile inter-phase. Most of the people these days are using their mobile phones to browse the internet. It is therefore important to have an inter-phase that can be operated by the computer and phones to make it accessible to all people.

The second feature is that it should be light. Generally, the websites are accessed with the use of internet bundles. If we have very heavy websites, they will take a long time for them to load and also use a lot of internet bundles. Use of heavy pictures and videos is one of the things that make a website to become excessively high.

The third requirement is to have a one reach inter phase. This is a situation where one can reach all the parts of the website from one page that one is in. This is the ability to get to all the website section from the home page or to all the other pages from any of the pages. The ease of navigation through a website is important so as to make the browser o be quick and to have a comprehensive reading of information in a website.

One of the functions that will be played by the website is that there it will be used to update the progress of the project. Each of the team members has their parts that they play in the project. Sometimes, these parts are done independently and the team members will upload their progress on the website sooner after for the other team members to update themselves. The site will also be used as the communication channel for the team and people that who care about the project. When the officials want to pass information to the team, they will upload it to the site and then the team and everyone will be able to access the information that has been uploaded and see it online.

The other function that will be played by the site is that of views giving and contribution making. There will be materials and prototypes that will be uploaded to this site. The team members will then be asked to make contribution opinions on the materials that will be uploaded to the site. From the contributions that will be made, the individuals that are responsible for the areas that needs to be changed will then make the changes that needs to be made. The other function that will be played by the site is that of sponsorship in terms of resources and knowledge. We need resources that will be used to make this project a success. We may be able to meet the basics but if we got some outside assistance in resources. We will



be able to make an even better device for the children. We also need technical assistance from people who have knowledge that may be of benefit to the project. To be able to reach these people who have the knowledge and the resources, we will direct them to the website.

The website was made simple since our purpose was fairly simple and straightforward. Once one got into the site, the first thing to see is the most current update from the group. Whatever a post is made, it goes to the news column and anyone in the group can be able to see it at the top of the stack of the posts that are made recently. These appear in a sequence that is based on how recent the posts have been made. On the menu of the site, we have the columns for the home, members, contacts, prototype and news. The home page has information about the project, why we are doing it, the rules that are needed for the project and a timeline of the execution of the project. The members' page has information about the members of the team. This includes their characters and the contributions that they are responsible for. The contacts section contains information about how to get into contact with the team in case one has a contribution that they want to make to the project progress. The prototype section will have details about the materials that will be used, the modelling of the baby go baby car and the dimensions. Finally, the news section will be the one that will be on the pop up once one gets into the site.

### ***5.2.7 Acceleration Analysis:***

In the following report, it discusses an analysis of the acceleration component for the Go-Baby-Go (GBG) capstone project. In previous GBG project vehicles, there has been an occurring issue of a "jerking" motion when a child presses the accelerator because the only speed control setting on the vehicles are stop and go. The "jerking" motion causes the children to be startled each time they drive the vehicles. The team chose this issue for focus on as a top design component to retrofit the Barbie jeep. The issue is addressed in the project by regulating the voltage power output from the battery to the drivetrain of the vehicle.

For the adjustment of a "smooth" acceleration, the team ensured that the motor output torque is greater than the mechanical load torque. The "acceleration time is important to avoid over-heating the motor due to the high starting currents" [13]. The following graph displays the ideal acceleration relationship between the torque and speed of the AC induction motor:

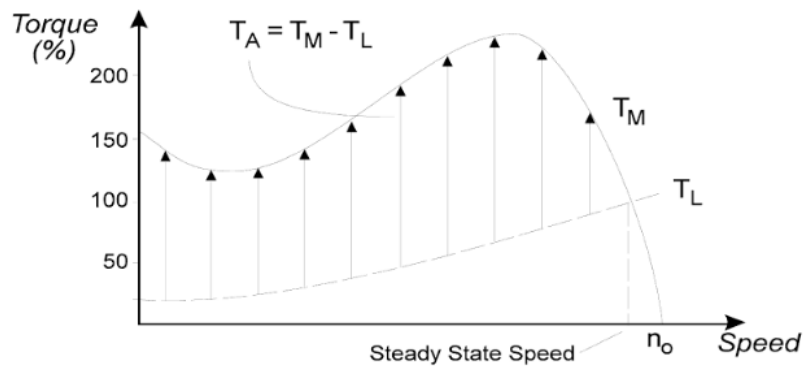

Figure 28 Acceleration torque at steady state speed [13]

Where:

- T<sub>A</sub> is the torque acceleration
- T<sub>M</sub> is the motor torque
- T<sub>L</sub> is the load torque

Another consideration in dealing with acceleration is the rate of acceleration of the system moving:

$$T_A = J \frac{d\omega}{dt} \text{ Nm}$$

Equation 1: Rate of acceleration of the system [13]

Where:

- J is the Inertia of the system
- w is the Rotational speed

The rate calculated needs to be constant throughout the time the system is moving until the maximum speed is reached. It takes the inertia and differentiates it between the rotational speed over time.

The following graph displays an ideal velocity over time with a gradual acceleration:

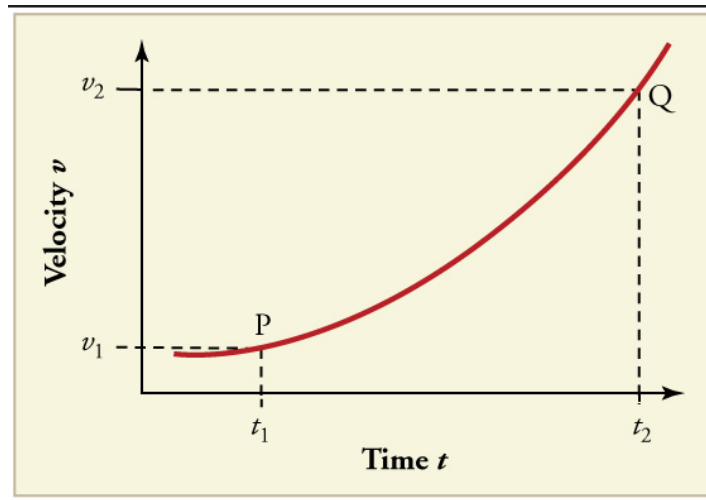

Figure 29 Ideal velocity over time graph with constant acceleration [14]

A rotary potentiometer is used as another resistor in the circuit, in which it will control the amount of current that is delivered from the battery to the motor. The orientation of the knob determines the amount of resistance applied to the current [15]. Depending on the number of terminals, it will be either an adjustable voltage divider or variable resistor. It will be attached to the stock battery and adjusted accordingly in resulting for a “smooth” acceleration.



Figure 30 Rotary Potentiometer [16]

The associated equation for an ideal voltage divider to determine the amount of voltage that the new circuit outs is as follows:

$$V_{out} = V_{in} \cdot \frac{R_2}{R_1 + R_2}$$

Equation 2: Voltage out [17]

Where:

- $V_{out}$ : Voltage out of the system

- $V_{in}$ : Voltage in the system

- $R_{1/2}$ : Resistance of resistor 1 and resistor 2

The battery voltage of the vehicle is  $V_{in}$ , the potentiometer and additional resistors in the vehicle are  $R_1$  and  $R_2$ , and the output voltage transferred out of the motors is  $V_{out}$ .

The switch from a power drill will be applied to the acceleration throttle of the vehicle because it is the most effective unit for variable speed acceleration. As one gradually applies pressure to the switch, there is an increase in current from the battery which will allow for a constant acceleration and eliminate the “jerking” motion. The following is an example of the switch:

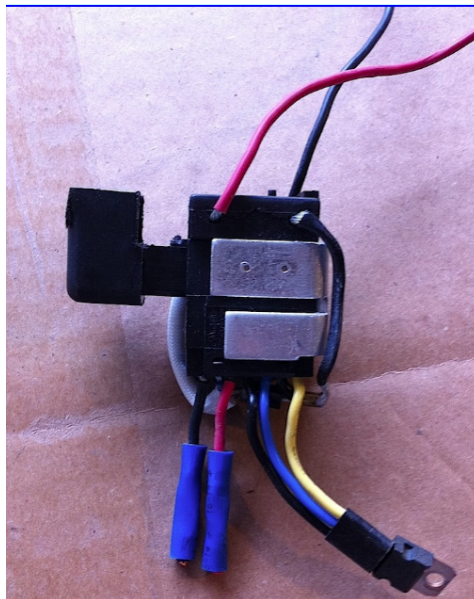

Figure 31 Power drill switch [18]

## 6 PROPOSED DESIGNS

First, the team realizes that our final model is not an invention that is entirely ours. The team built on a model that was made to the car to make it ideal. The first thing that was implemented to do is to make a power strategy for the design. The second is the modification of the steering wheel, and the third is the modification to the seat to include a harness that can be used to strap a child into the seat. This sort of engineering is called fabrication of the prototype. From the analysis that was made, the new model is more superior in terms of the safety of the kid, the comfort of the kid and it is effective in terms of its economic viability. The most important

thing is that a kid can be able to ride the car with their disability following the changes that are to be made. This is the main point and agenda that is propelled by the Go Baby Go project.

To implement the design proposal, the team made the proposed changes to the existing design. The changes that needed to be done is not all that complicated. First, the change from the circular steering to the bar steering is relatively easy. This is because all that needs to be done is to remove the circular steering and put an improvised PVC pipe steering wheel that is linear. The second change entails the installation of a seat harness to the kid seat. This was done easily. The only thing that will be done is the purchase of the harness and then installation of it by riveting. Finally, the only thing that may be a little complex is the installation of the battery. This will not be too much complicated given that the current car has a battery that we will just replace with the new one that has three dials for the levels of speed. In Appendix A, a short bill of material is placed there.

## **7 IMPLEMENTATION**

### **7.1 DOE**

The team developed design of experiments to validate the design of the project. There are separate experiments that focus on 2 areas of the vehicle that will be conducted; steering and safety. A variable in the experiment will be the step size of the speed the vehicle will reach over a given amount of time. The portion of the code was adjusted per trial to obtain a constant vehicle speed. Another test factor involved in this specific experiment will be the type of surface the vehicle is driven on. The deceleration will be examined as how quickly the vehicle is able to come to a complete stop from maximum velocity. The amount of time over a certain distance will be recorded.

The steering component experiment was tested on the response time that the vehicle is able to turn its wheels to the full degree of left and right and return back to center alignment. Similar to the acceleration component experiment, the interval size of the signal was adjusted. The type of surface the vehicle is driven on is another variable that was adjusted.

The statistical results that occurred was that due to malfunction in the motor acceleration, the wheels did not go back to the center, and for that the child could not go straight.

The results mean that unfortunately the ride-on-car did not hit a high expectation. As for the manufacturing, the schematic that was done was good enough, but the access of the motor controller was tough and had a glitch.

### **7.2 Manufacturing**

During the manufacturing process, the team came together and wrote down all the details on what parts the team is going to need to start working on the ride-on-car. As the team sat down, the first thing that was done is putting all information on what parts of the ride-on-car needs to

be retrofitted. As shown below in figure 32, a quick schematic was put together to show the base of what needs to be connected to what part.

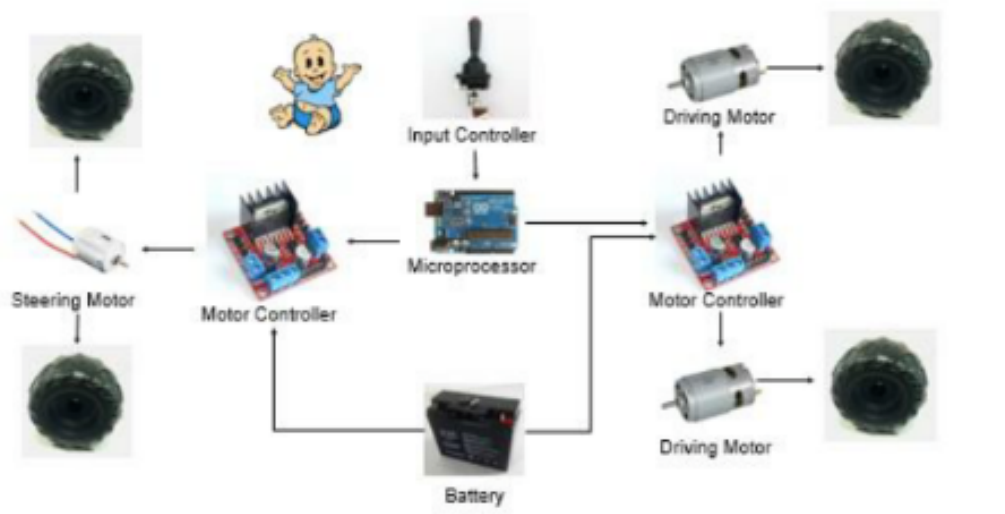

Figure 32 Schematics of The Parts

Firstly, the steering wheel. The team needed to think of a way to retrofit the steering wheel that many children could control; therefore, a universal steering wheel. Many children can not hold on to the steering wheel, therefore, the team found a joystick that is shown in figure 33 below. This joystick is to be replaced with the steering wheel, and that will help the child to just press on the button and the car would move. As soon as the child remove their hand off the joystick, the car would stop. The joystick will not only be going in the y-axis but also in the x-axis.

Due to the joysticks' and accelerations' problem, the ride-on-car would need a new motor. The motor was the team's major problem. With all the motors that the team looked for and bought, the team finally found a motor that will be tested as soon as it arrives. The servo motor that the team ordered is needed because the motor that is in the ride-on-car came with an axle motor, which would not move properly and appropriately with the joystick and acceleration controller.



Figure 33 Joystick

Safety is one the most important aspect of all. With safety, the child and their parents feel comfortable. Safety could help the child from getting hurt. With that, shown in the bill of material table below, a couple of PVC-pipes are ordered and the team is waiting for its arrival will be surrounding the car. The PVC-pipes will be covered with foam so it would not hurt the child. Another safety aspect the team came across is the seatbelt. The ride-on-car came with its seatbelt but it was not enough. The team has ordered a similar looking car seat shown in figure 34 below, where the seat is cushioned and has a 5-point harness that will help the child from any sudden crash or even just hitting the wall. With the force if by any chance hits a wall, the 5-point harness cushion will be drilled in the PVC-pies and will reduce the force of the child being hurt.



*Figure 34 Car Seat with a 5-Point Harness*

Lastly, to connect all of motor, joystick, and speed controller; the team needed an Arduino. With the help of the professors, the team ordered an Uno 3 ultimate starter kit. With the Arduino, and the correct use of codes, all of the electronics should go as planned. The microprocessor is connected to two motor controllers which are both connected to the battery. The first motor controller is connected to the steering motor and connected to the wheels. While the second motor controller are connected to the driving motors then to the back wheels.

Shown below in appendix A, is a bill of materials with all of the parts that the team had ordered from the beginning of the last semester. The blue highlighted parts are technically what the team had planned to use. As for the old stuff, the team did not see them useful and will hopefully return them back. For the budget which concludes all what the ride-on-car will cost a parent to build it, is below in figure 34.

Budget		
Part Categories	Pricing	Source
Safety	\$ 61.24	Home Depot
Electronics	\$ 66.97	Amazon
Steering	\$ 24.95	Amazon
Vehicle	\$ 187.67	Amazon
<b>Total Vehicle Cost:</b>		<b>\$ 340.83</b>

Figure 35 Budget

The team implemented safety parameters onto the vehicle by sliding the PVC foam concentrically over the PVC pipes and drilling holes through the PVC. Screws were placed through the holes to attach the PVC to the vehicle. The 5-point safety harness was also placed on the plastic seat that came with the car.

As shown in figure 36 below, is a picture of the CAD that the team had drawn using the

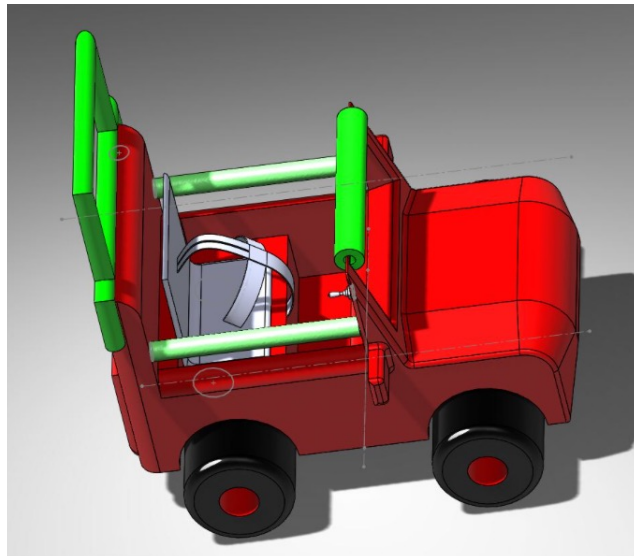

Figure 36 CAD Drawing

computer. In figure 36, the team shows was placed on the car, and how the car looks like. In figure 37 below, is the final design of the car after putting all components in the car.





*Figure 37 Final Design*

## **8 Testing**

The design requirements that the team got through with was first the low cost. The team made the cost of the car to be approximately \$341. The second test is the ease of assembly. The team had made a solution manual that will be a reference to all parents who would like to build or even retrofit the same car. For the durability test, the team had used the car on many surfaces, such as tile floor, and wooden floor. Also the car was tested for being light weighted. The car was easily moved from one place to another with two of the team mates carrying it around. For being aesthetically, the team left the ride-on-car with the lights and made the cushion to look like it came with the car. As for safety, and for the major testing such as riding the car, due to liability issues, the car could be used by any child. Therefore. Major testing was not available.

## **9 Conclusions**

### **9.1 Contribution to Project Success**

During this project, the team's goal and purpose was not completely satisfied. The team retrofit a ride-on-car to make it suitable for the children and their parents. Unfortunately, the team couldn't the car to be stable. Although, the team worked cohesively and effectively. The final deliverable was not a success, as the one of the motor controller burnt down before the day of the delivery of the ride-on-car. The motor controller that burnt was connected to the joystick. Another bump the team faced that was not a success is getting the ride-on-car to gradually accelerate for the child not to feel the jerking motion the ride-on-car gives.

As for the ground rules the team put together, yes the team met every Thursday, but the time frame got changed from 5 to 8 p.m., due to the team's schedule. With the load of work, the

team had to accomplish, the team added more times in their schedule to meet. The team also helped out whom couldn't come to one of the meetings. With that, the team was open-minded to new ideas and creative words that could help the project. All ideas were appreciated by all team members. With all ideas that was shouted out, the team worked together and choose effectively and respectfully the ideas that would and could work with the project. Team meetings were professional, unless the team was having a break, then the team went off-board the topic. As for team decisions, the team conducted majority voting's on all matters that were needed.

The team's most positive performance was keeping the budget low. The total project for buying the ride-on-car and its components to build is about 340\$. Trying to find cheap, but good parts was hard, but the team, stayed focus on that perspective a lot. The team wanted to make the parents feel comfortable into buying a low budget project that can be with them for a long time, or when it needs an update.

The most negative aspect of the project performance was time management. Due to time management, the team had to sum up the whole project and did not have enough time to review nor had enough time to work on the project's issues and malfunctions. Due to the time management it did affect many performances such as the product quality. Due to not having time to refurbish the wrong dues on the ride-on-car. The team submitted a poor quality of the ride-on-car. At the end, and before submitting the car, one of the motor controllers, as stated above, stopped working and burnt down, and with the poor time management, and leaving everything to the end, the team did not have anymore time to buy a new one.

One of the good methodologies that was used and was a benefit to the team was the staff meetings. The staff meetings helped the team to recognize what is missing, or what the team could look into more deeply. Another methodology as a team might say was the references the team used. The references that the team consulted were the professors that gave the team their time and contributions to help the team build up the knowledge that was needed.

As for the negative methodology that team had was not having backup equipment's. During the end, where the motor acceleration burnt down, of the team had a backup, the project would have been working. But due to the team not having more equipment's, the ride-on-car did not function.

Another methodology that was a big negative on the team was not having a backup plan. Due to almost having all equipment's to be electrically modified, the team should have had an easy manual solution, just incase anything happens or goes wrong, and it did. The team should have come up with other solutions for something like this.

A major problem that the team encountered was losing the acceleration motor. Due to a mistake one of the teammates switched the polarity which made the acceleration motor burn. With that, the ride-on-car was not able to function due to the team's deadline. The acceleration motion that burnt down was connected to the joystick, and disabled the joystick's movement.

A specific organizational action that can be taken to improve performance was to start earlier than when the team did. The team had some issues with learning how to function the micro processor (Arduino) and started to work on the ride-on-car very late. The team had many ideas, but non was put into place due to the shortness of time. The team started to work on coding about three or 4 weeks prior to the due date of the project, which made everything cramped up together, and not enough time to resolve the new problems that occurred.

A technical lesson that the team has learned was to be more open on what each person had in mind. Communicating is the main and the most important aspect in any group. Having a group and working is easy, but having the write tools for communication is the major affect. One example is not just talk to each other, but also looking at which field the team is going to work with. Due to the ride-on-car being a sum of EE major, the team was slow into asking help from Dr. Yaramsu. As the professor is from the EE department, if the team had spoken earlier, the team might have been working on the ride-on-car a bit earlier.

## 9.2 Opportunity for Improvement

The team has a plan to improve the ride-on-car. The biggest improvement is being better with managing time. having to plan ahead of time could be better for all parties. If there was more time, the team would have replaced the burnt motor controller. Improvements to the ride-on-car can be made to make the car more efficient. A problem occurred at the end of the project which was not being able to straighten the wheels and allowing it to go back to center alignment. With having more time, the team could have or even the next team taking over the project could figure out a code that will re-center the wheels. Another improvement to the ride-on-car that can happen is to try to place a code into Arduino the help reduce the jerking motion.

## 10 REFERENCES

- [1] Sam logan. "Why the time is right for a radical paradigm shift in early powered mobility: the role of powered mobility technology devices, policy and stakeholders". Retrieved 25 September 2016, from <http://www.ncbi.nlm.nih.gov/pubmed/26340446>
- [2] C. Beeler, "Toddlers take the wheel: Harnessing toy cars for mobility," in <http://www.newsworks.org>, Newsworks.org, 2013. [Online]. Available: <http://www.newsworks.org/index.php/local/healthscience/51646-toddlers-take-the-wheel-harnessing-toy-cars-for-mobility>. Accessed: Sept. 26, 2016.
- [3] D. Kukich, "UDMessenger - harness house , Flights of joy," in <http://www.udel.edu>, 2015. [Online]. Available:<http://www.udel.edu/udmessenger/vol21no4/stories/research-harness-house.html>. Accessed: Sept. 26, 2016.
- [4] J. Burnham, "Go Baby Go gets Disabled Children on the move," in <http://www.ccsucares.com>, 2015. [Online]. Available: [http://www.ccsucares.com/wp-content/uploads/2015/02/Go-Baby-Go-gets-disabled-children-on-the-move-Central-Connecticut-Communications\\_-News.pdf](http://www.ccsucares.com/wp-content/uploads/2015/02/Go-Baby-Go-gets-disabled-children-on-the-move-Central-Connecticut-Communications_-News.pdf). Accessed: Sept. 26, 2016.
- [5] John hawks herald . 2016. Toy car steers physical, social mobility for child with disabilities . Feb 9, 2016. The OTTAWA HERALD News. [Online]. [26 September 2016]. Available from: [http://www.ottawaherald.com/news/local/toy-car-steers-physical-social-mobility-for-child-with-disabilities/article\\_c6aacda0-c695-5a7c-ba5f-7505a0bb1527.html](http://www.ottawaherald.com/news/local/toy-car-steers-physical-social-mobility-for-child-with-disabilities/article_c6aacda0-c695-5a7c-ba5f-7505a0bb1527.html)
- [6] J. Östlund, "Joystick-controlled cars for drivers with severe disabilities," Swedish National Road and Transport Research institute, 1999.
- [7] Androva1, "Making the Fisher-Price ride-on toy go full speed," in *YouTube*, YouTube, 2010. [Online]. Available: <https://www.youtube.com/watch?v=7WLroaqIjOk>. Accessed: Sep. 30, 2016.

- [8] H. Huang and J. C. Galloway, "Modified ride-on toy cars for early power mobility: A technical report," vol.24, no.2.[Online].Available:  
<https://www.ncbi.nlm.nih.gov/pmc/articles/PMC3324847/>. Accessed: Sep. 30, 2016.
- [9] "The original PlasmaCar,". [Online]. Available: <http://plasmacar.com>. Accessed: Sep. 30, 2016
- [10]"Force fields," UD GoBabyGo!, 2015. [Online]. Available:  
<http://sites.udel.edu/gobabygo/harnesses/>. Accessed: Oct. 1, 2016.
- [11] Boundless. "Centripetal Force." Boundless Physics. Boundless, 26 May. 2016. Retrieved 19 Nov. 2016 from <https://www.boundless.com/physics/textbooks/boundless-physics-textbook/uniform-circular-motion-and-gravitation-5/velocity-acceleration-and-force-53/centripetal-force-258-4350/>
- [12] "An Unbanked turn,". [Online]. Available:  
[http://www.batesville.k12.in.us/physics/phynet/mechanics/circular%20motion/an\\_unbanked\\_turn.htm](http://www.batesville.k12.in.us/physics/phynet/mechanics/circular%20motion/an_unbanked_turn.htm). Accessed: Nov. 19, 2016.
- [13] M. Barnes, Practical variable speed drives and power electronics. Newnes, 2003. [Online]. Available:  
[https://books.google.com/books?id=LxW9F9WCixcC&pg=PA48&lpq=PA48&dq=variable+speed+acceleration&source=bl&ots=7siDKBZcpL&sig=R4jzmvWBnvmxtki0M3FXNrHGBXg&hl=en&sa=X&ved=0ahUKEwi\\_9fHhyLHQAhUri1QKHZeGAMwQ6AEIMjAE#v=onepage&q=variable%20speed%20acceleration&f=false](https://books.google.com/books?id=LxW9F9WCixcC&pg=PA48&lpq=PA48&dq=variable+speed+acceleration&source=bl&ots=7siDKBZcpL&sig=R4jzmvWBnvmxtki0M3FXNrHGBXg&hl=en&sa=X&ved=0ahUKEwi_9fHhyLHQAhUri1QKHZeGAMwQ6AEIMjAE#v=onepage&q=variable%20speed%20acceleration&f=false). Accessed: Nov. 14, 2016.
- [14] [Online]. Available: <http://devarchive.cnx.org/contents/ef1e90b2-9c2d-4d35-9faa-d1055b8d89db@5/graphical-analysis-of-one-dimensional-motion>. Accessed: Nov. 18, 2016.
- [15] B. H. Inc, "How does a potentiometer work?," Brighthub Engineering, 2009. [Online]. Available: <http://www.brightengineering.com/commercial-electrical-applications/47625-potentiometers-explored-construction-and-working-principles/>. Accessed: Nov. 17, 2016.
- [16] Member, "Break away Headers - straight," 2015. [Online]. Available:  
<https://www.sparkfun.com/products/9939>. Accessed: Nov. 17, 2016.
- [17] Contributors and J. O, "Voltage Dividers,". [Online]. Available:  
<https://learn.sparkfun.com/tutorials/voltage-dividers>. Accessed: Nov. 17, 2016.
- [18] "Modified power wheels race cars with variable speed pedal and rubber tires,". [Online]. Available: <http://www.saltydog.com/powerwheels/>. Accessed: Nov. 18, 2016.
- [19] "Revolutions per minute," in Wikipedia, Wikimedia Foundation, 2016.

[Online]. Available: [https://en.wikipedia.org/wiki/Revolutions\\_per\\_minute](https://en.wikipedia.org/wiki/Revolutions_per_minute). Accessed: Nov. 19, 2016.

[20] "Typical maximum steering angle of a real car," 2016. [Online]. Available: <http://gamedev.stackexchange.com/questions/50022/typical-maximum-steering-angle-of-a-real-car>. Accessed: Nov. 19, 2016.

## APPENDIX A: Bill of Materials

### Bill of Materials:

Item	Part Name	Qty	Description	Cost	Link
1	Hub AM-2279	1	Motor	\$15.00	Andymark.com
2	Window Motor AM-2235	1	Power Steering	\$39.00	Andymark.com
3	Big Dome Push Button-Red	1	Button	\$16.95	Amazon.com
4	6- Volt Rechargeable Battery	1	Battery	\$29.40	Amazon.com
5	Universal Baby 5-Point Harness Belt	1	Seatbelt	\$9.98	Amazon.com
6	Power Wheel Switch	1	Switch	\$9.99	Powerwheels.com
7	Hobbypark HDR315M 15kg Digital High Torque Robot Servo	1	Servo Motor	\$29.99	Amazon.com
8	Best Choice Products 12V Kids Ride on Truck Car W/ Remote Control	1	Ride-On-Car	\$189.67	Amazon.com
9	Kuman L298 Motor Drive Controller Board	2	Motor Controller Board	\$17.98	Amazon.com
10	RioRand Upgraded 6V-90V 15A Motor Pump Speed Controller	1	Speed Controller	\$10.99	Amazon.com
11	Arduino Uno 3 Ultimate Starter Kit	1	Arduino	\$48.99	Amazon.com
12	Arcade Joystick with Top Fire Button For Crane and Claw Style	1	Joystick	\$24.95	Amazon.com

	Games				
13	KVH3323 Kraken Ts-555HV Digital Torque Servo	1	Servo Motor	\$123.13	Amazon.com
14	Child Booster Seat Car Chair for Kids	1	Car Seat with 5-Point Harness	\$10.96	Dhgate.com
15	1" Long Foam Pipe	2	Foam Pipe	\$3.98	The Home Depot
16	1"X2' PVC Pipe	5	PVC Pipe	\$9.90	The Home Depot
17	1" PVC EL 90D 5PCK	1	Elbow	\$2.55	The Home Depot
18	1" PVC EL 90D	2	Joint	\$1.96	The Home Depot
19	1" PVC TEE	2	Tee	\$2.44	The Home Depot
20	Sheet Screw	2	Screw	\$2.36	The Home Depot
21	Sharkie 5/16"	1	Screw	\$2.68	The Home Depot
22	Red 22 - 18 AWG 0.250 Fully Insulated F-Disconnects	2	Female Connecters	5.98	The Home Depot
23	Blue 22 - 18 AWG 0.250 Fully Insulated M-Disconnects	2	Male Connector	5.98	The Home Depot
24	25 ft. 16 Red Stranded CU Primary Wire	2	CU Wires	10.4	The Home Depot
<b>Total Cost Estimate:</b>				<b>\$625.26</b>	
<b>Total Remaining:</b>				<b>\$874.74</b>	